

# Innovative Digital Instrumentation for Geotechnical Monitoring Systems

A.J. Hyett  
*YieldPoint Inc.*

## ABSTRACT

Due to the ongoing revolution in electronics and communications more cost-effective geotechnical instruments can be manufactured using digital technology. This new generation of digital instruments have embedded microcontrollers that provide highly accurate and reliable measurement of geotechnical behaviour in *real world units* that can be immediately interpreted. Digital measurements can be transmitted across existing mine-wide wireless communication networks, interfaced directly with infra-red enabled PDA's or PC's, and parsed to memory by low-cost data-loggers.

## Introduction

Instrumentation is deployed to monitor ground conditions in many underground mines, from those operations with a few GMM's (Ground Movement Monitors), to those with elaborate mine-wide micro-seismic systems. Some possible questions that may lead to the installation of geotechnical sensors are:

- Is the stability of the excavation adequately controlled?
- Is a component of the support system being overloaded?
- What is the magnitude and distribution of load in the support?
- What are the trend, rate and magnitude of ground movement?
- Are protective methods (i.e. backfilling, shotcreting, rehabilitation) achieving their purposes?

Historically, geotechnical instrumentation has been based on **analog** sensors, so that the user measures resistance, voltage, current (4-20mA) or vibrating wire frequency, which must then be converted into displacement, stress, load *etc.* This paper discusses the compelling opportunities that derive from the application of new **digital** sensor technologies to underground geotechnical monitoring.

## Analog Geotechnical Instruments – The Past

For mining applications geotechnical sensors are often used according to scenarios that are radically different from the civil engineering applications for which they were designed. In 1996, when the author co-founded Mine Design Technologies Inc. (MDT), the primary aim was to reduce the cost of ground monitoring instrumentation, so that mines could more cost effectively install sensor clusters providing sufficient spatio-temporal data to answer the questions listed above.

However, reducing the cost of the instruments was only a part of the solution. There are two main reasons for this.

First, a dedicated team of experienced engineers and technicians is required to perform the following tasks surrounding any instrumentation program:

- procurement of the instrumentation hardware and software
- installation of the instrumentation and protection of lead-wires
- establishment of baseline readings
- maintenance of the instrumentation during the project (e.g. splicing damaged lead-wires)
- establishment of a data collection schedule
- collection of the data
- interpretation and reporting of data, and
- formulation and implementation of necessary response actions.

The expense associated with these tasks, especially data collection, comprises a significant hidden component of the overall instrumentation program cost.

Second, the interpretation of analog geotechnical sensor data interpretation is often confused by the severe limitations associated with analog sensor technology. In particular:

- The transformation of esoteric analog data into real world units presents opportunities for errors to be made by unskilled personnel.
- Poor sensor performance due to: (i) limited accuracy especially for sensors designed for long boreholes, (ii) no correction for errors related to lead-wire length for resistance or voltage output sensors, (iii) no provisions being made for temperature compensation when deployed in situations, such as backfill monitoring, where thermal variations occur.
- Poor reliability usually related to (i) unstable analog signals due to minimal water ingress or minimal cable damage, and/or (ii) damage to delicate electrical/mechanical transducer systems due to blasting.

In fact, during data interpretation the greatest challenge is created, not by the sensor that fails completely, but by the sensor that is apparently operational but is transmitting an erroneous signal due to partial malfunction or lead-wire damage.

For these kinds of reasons, geotechnical sensors remain under-utilized in underground mines where they are seldom perceived as an effective tool for day-to-day decision making by mine personnel. Furthermore, they are rarely deployed in active stopes during the production cycle, where potentially they can have the greatest impact on safety and efficiency.

## **Digital Geotechnical Sensors for Ground Monitoring – The Future**

The design of sensors has been transformed by the ongoing revolution in computation and telecommunications. A decade ago state-of-the-art sensing technology was largely confined to government, military and university laboratories. Today low-cost, mass produced commercial components represent the state-of-the-art. This, combined with the explosion of sensor utilization in the automotive industry, means that electronics can be used to manufacture **digital** geotechnical sensors. This new technology affords tremendous opportunities for monitoring, and improving safety in the underground mining environment.

*What is a digital sensor?*

By definition digital sensors transform continuous signals from analog transducers, into discrete digital output signal encoded as 1s and 0s. The most cost-effective electronic platform for a digital sensor is a programmable microcontroller unit (MCU) with an 8 or 16-bit core, memory, timers and counters and ADC (Analog to Digital Converter)'s packaged into a single integrated circuit (IC). An MCU can perform a myriad of signal conditioning tasks including:

1. multiplexing power to excite multiple transducer elements (e.g channels of displacement data from Multi-Point Borehole Extensometers),
2. using the MCU's on-board ADC's, timers or counters to perform measurements by converting the transducer output signal which may reflect changes in resistance, impedance, voltage, or current into a digital code, ,
3. filtering the measurements using *over-sampling* techniques. i.e. making 10 000 measurements over a 1 second period to obtain an average measurement with a lower noise floor,
4. improving linearity usually through a piece-wise linear algorithm based on a look-up table stored in the EEPROM or Program FLASH memory,
5. converting the measurement into real world units by applying conversion factors,
6. applying temperature compensation based on a temperature measurement, and finally
7. transmitting a robust digital communication signal on a single wire.

The main benefits associated with this added functionality are: (i) to transform an esoteric transducer output into real world units that can be immediately and routinely interpreted, and (ii) to convert a weak signal from the transducer into a robust signal that lends itself to transmission in the harsh mining environment.

*Five reasons why digital sensors better*

1. **Improved Accuracy.** Digital sensors are individually calibrated by the manufacturer after assembly is completed. Therefore variations related to component specifications and assembly processes are eliminated;
2. **Improved Reliability.** Reliability is the biggest single issue that jeopardizes the interpretation of sensor data. Digital sensors can utilize highly reliable yet low cost transducers such as those widely used in automobiles. By embedding the signal conditioning electronics within the sensor, a stronger and more noise-immune signal is transmitted, resulting in a more noise-free and drift-free signal for the end-user. Digital signals such as a frequency modulated output can be sent over long lead-wires (>500m) without distortion or errors (not true of resistance or voltage signals).
3. **Improved Accessibility to Data.** Data from digital sensors is converted to real-world units within the sensor, and therefore measurements inform even unskilled personnel. Furthermore, almost any digital device, a PC, a PLC, a PDA running PalmOS or Windows CE, or a wireless phone or modem, can access the information. Data-logging for digital sensors is remarkably simple (see SLUG data-logger below).
4. **Simpler Data Management and Storage.** For analog sensors the most immediate task of data-management is to invert the measurement from ohms, volts, mA or Hz into the physical measurand of interest. This task is usually conducted using an eXcel *spreadsheet*. For digital sensors, the data already exists in real world units, and so can be automatically written into a structured *database* application, with built-in storage and retrieval capabilities. Such applications have the capability to implement thresholds based on a number of criteria. When a critical threshold is exceeded e-mail alerts can be sent, and the offending sensor's data can be automatically uploaded using FTP to an internet server, where they can be viewed by authorized personnel. Such alerts are made more actionable (i.e. credible) because of the improved accuracy and reliability of the digital sensors.
5. **Reduced Cost.** Embedding digital capability in a geotechnical sensor adds an incremental cost of <\$5-10 per unit, but this cost is offset many times over by the following factors.
  - Digital sensors can leverage low cost transducer technologies widely used in the automotive industry that assume a MCU will be present to manage the transducer.
  - Digital sensors can improve the accuracy a low-cost transducers. For instance, a low-cost transducer with a specified linearity of 5%F.S.(e.g. 5mm for a 100mm displacement transducer) is not acceptable for most instrumentation purposes. However, individual calibration and a piece-wise linear correction can readily improve the linearity of the sensor to 0.5%F.S. or better, which in all but the most accurate applications will be acceptable.
  - Digital sensors require only one signal wire for output, whereas analog sensors usually require a wire for each data channel. For long-range deployments, when lead-wire can be a major component of the total instrument cost, the savings are significant (an order of magnitude greater than the cost of the digital MCU). Furthermore simpler plugs can be used (or even just alligator clips) to connect the sensor to the reading unit or data-logger.
  - A single readout unit can service all types of sensors, even though the transducer components for each type may be radically different. The digital readout units themselves have programmable capability (i.e. upgradeable firmware in FLASH memory) so that they will never become obsolete. Data-loggers and all other peripheral devices also have programmable memory.

These advantages result in a price saving of approximately 30-50% for digital geotechnical instruments compared to analog predecessors, and 50%-80% for the associated peripheral units such as data-loggers.

## A Digital Geotechnical Instrumentation System for Mining.

Currently, the only digital instruments for mining application are very expensive, high end products, such as retrievable borehole inclinometers. YieldPoint Inc. is a new mining instrumentation company that designs, manufacturers and markets low-price digital geotechnical instruments specifically for the mining industry. Figure 2 represents the architecture of YieldPoint’s digital sensors (top) and peripheral (readout) units (bottom). The two may be connected by a signal wire or RF wireless connection.

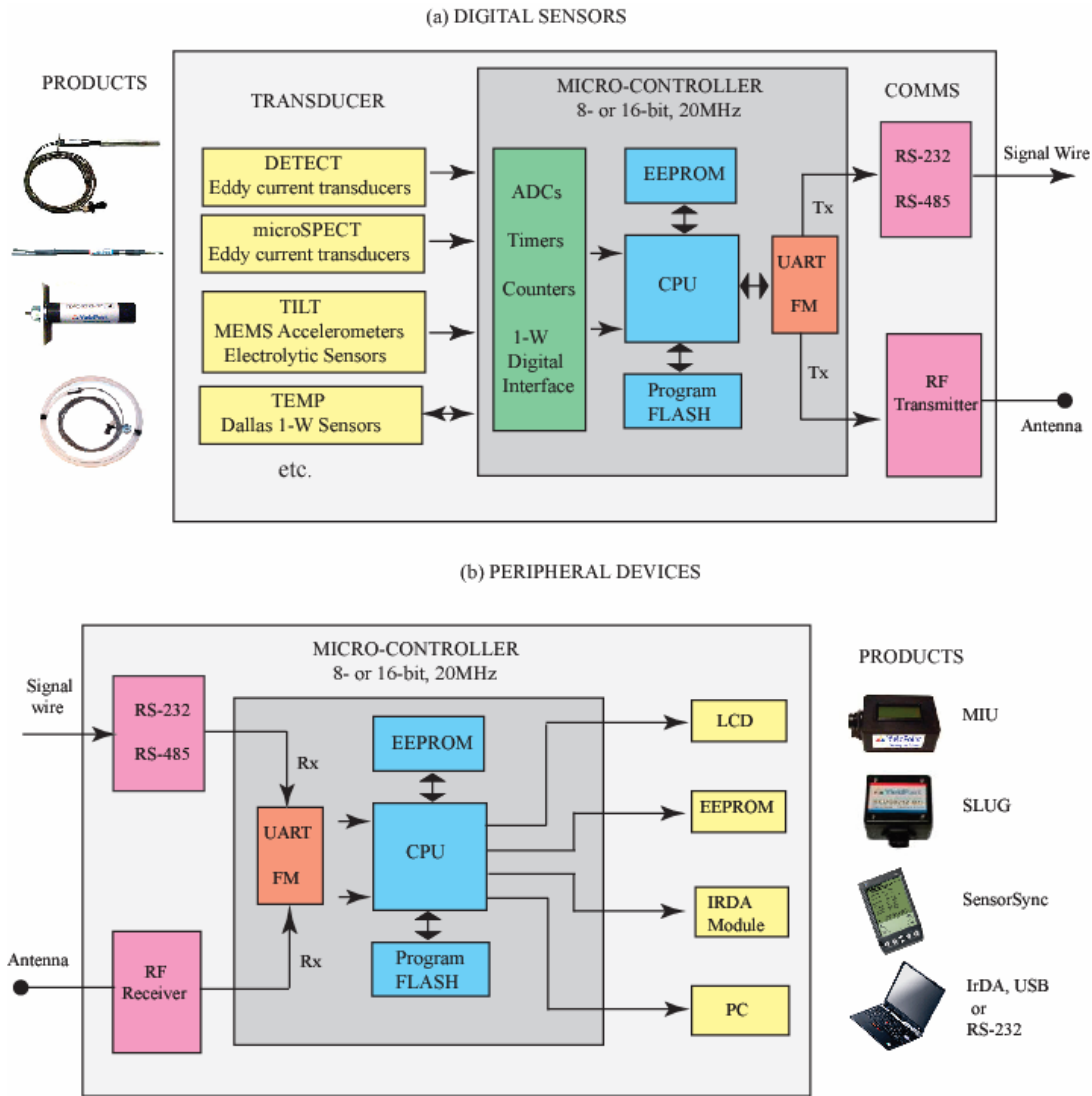

Figure 2: YieldPoint’s digital sensor architecture. The upper diagram indicates the functionality of the sensors themselves and the lower diagram that of the peripheral units that read the data.

## Digital Sensors

### DETECT (Digital Extensometer Technology with Eddy Current Transducers)

Measurement of movements around underground excavations is perhaps the most fundamental indicator of instability. The main instruments used for this purpose presently are GMM's and Multi-Point Borehole eXtensometer (MPBX)s. Currently, the transducer technology in these sensors is almost exclusively based on potentiometers, usually configured as voltage dividers. Although potentiometers represent an acceptable transducer for controlled laboratory-type environments, it is widely accepted that they are environmentally unstable (Fradden, 1996). In contrast, eddy current sensors, which operate on an inductive principle, are used for monitoring some of the toughest applications conceivable: piston location in motors, pneumatic valve control, location of rods in nuclear reactors where they are submerged in liquid sodium, and down-hole oilfield borehole callipers. In fact, for industrial proximity sensing eddy current technology is the most widely used solution. The main advantage of induction technology is that it is "non-contact", so that the electronics can be hermetically sealed from the harsh environment, and there is no physical interaction between the moving part and the transducer that can be damaged over time. YieldPoint has adopted long range eddy current transducers for its DETECT displacement sensors because these characteristics are especially advantageous for mining applications.

For single point displacement measurement, a digital DETECT-GMM (Figure 3) costs around 50% that of a potentiometric alternative. For multiple point measurements, YieldPoint has developed extensometers using a completely revolutionary *Single Rod Design* (Figure 4) that locates the displacement transducers at specified distances along the instrument. By virtue of this design movement is measured directly at the point of occurrence. The accuracy of the transducer represents that of the overall instrument through the elimination of errors associated with conventional MPBX technology, such as: (i) the sag of multiple extensometer rods, (ii) friction between extensometer rods especially when probe is subject to shear, (iii) thermal expansion of extensometer rods, and (iv) a bulky extensometer head assembly where displacement transducers are housed. For the **DETECTOR** product line the electronics can be retrieved from the instrument after monitoring, so dramatically reducing the Total Cost of Deployment.

Finally this unique design also creates advantages with respect to the manufacturing process, which is reflected in digital borehole extensometers which cost approximately 30-50% the price of equivalent analog products.



Figure 3. The DETECT GMM

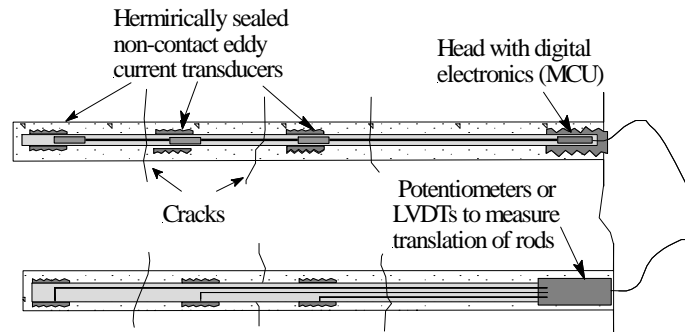

Figure 4. The single rod extensometer design (above) compared to the conventional multi-rod approach (below).

## TILT (Tilt, Inclination and Leveling Technology)

YieldPoint's TILT technology can be employed for applications such as (i) mining under backfill, (ii) crown pillar stability, (iii) slope stability and (iv) monitoring brows.

### *TILT-SG using MEMS Accelerometers*

In recent years, MicroElectricalMechanical Systems or MEMS sensors have made tremendous advances in terms of cost and level of on-chip integration for measurements such as acceleration, vibration and tilt. Micro-machined accelerometers are now being mass produced and incorporated into products such as joysticks and airbags, applications that were previously impossible due to sensor price and/or size. MEMS accelerometers can measure both dynamic accelerations due to shock or vibration and static accelerations due to gravity. YieldPoint employs a MEMS accelerometer as the transducer component of the TILT-SG30, a dual axis in-place-inclinometer (IPI) system which measures angle of tilt over the range +/- 30 arcdeg to a resolution of 0.01arcdeg.

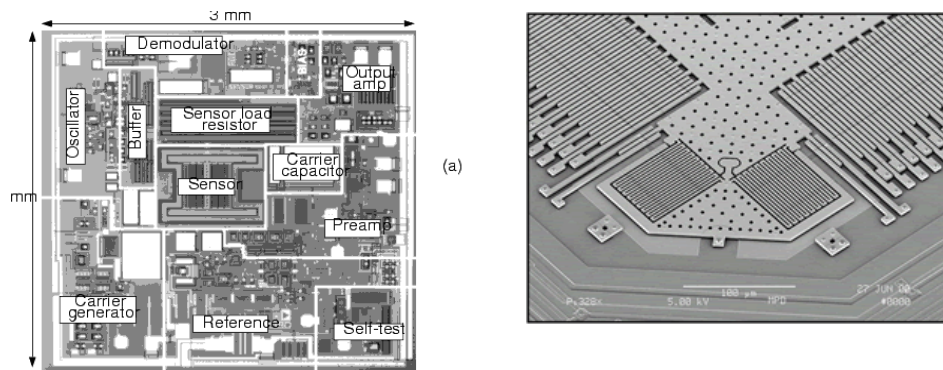

**Figure 5 . Details of the MEMS micro-machined integrated accelerometer used in YieldPoint's TILT-SG technology. (LHS) Chip overview, (RHS) close-up of transducer structure showing central trunk beam and fingers. (Analog Devices, Inc.)**

A very much larger opportunity for MEMS accelerometers in mining is in the development of fully **digital seismic systems** based on direct to digital sensors. Such sensors can dramatically reduce the cost of geophones and allow the direct-to-digital data transmission to leverage the existing mine-wide communication systems.

### *TILT-EL using electrolytic tilt sensors.*

For TILT applications requiring higher resolution YieldPoint employs an electrolytic tilt sensor which has a resolution of 1 arc sec (1/3600 of one arc degree) over a range of +/- 2arcdeg.

Although the two tilt sensors described (TILT-SG and TILT-EL) are based on entirely different transducer technology the digital MCU in both provides identical output signals that interface seamlessly with any peripheral device.

## Peripheral Devices

### SLUG (Sensor Logger for UnderGround)

As mentioned above, data-logging applications for digital sensors are incredibly simple and cost-effective. Virtually no configuration is required because a digital sensor can identify itself and tell the data-logger how many channels of data to expect. The data-logger simply reads the sensor output signal then parses the information into memory. The end-result is data-logging solutions that are small, low-power, easy to use, and cost up to 80% less than existing products.

Figure 6 shows YieldPoint's single instrument data-logger which can take 1 reading/hour for 100 days powered by a single 9V alkaline battery. Any digital sensor is simply plugged into the data-logger which will automatically switch on and start to read. When the digital electronics

within the data-logger are put into sleep mode between readings the MCU draws only nano-watts of power.



Figure 6. The SLUG data-logger

### SENSORSYNC – PalmOS readout for digital sensors

Figure 7 shows the output from YieldPoint's digital GMM using a PalmOS device. In this case the digital sensor plugs into a SensorSync Module that communicates with the PalmOS device using its infra-red (IrDA) port. Notice that the data immediately exist in real world units (RHS), and is compared with pre-existing data in the database to indicate a rate of movement (mm/day).

EDIT SENSOR INFORMATION	REVIEW DATA	SENSOR READING																					
<b>ID:</b> HBMS - 0212-22-95 <b>TYPE:</b> ▾ DETECT <b>MODEL:</b> ▾ GMM 3-EX 4-EX 6-EX ▾ <input checked="" type="checkbox"/> METRIC <b>ANCHOR DI:</b> 0.00 m <b>PURPOSE FOR SENSOR:</b> ..... ..... <input type="button" value="OK"/>	<b>ID:</b> HBMS-0212-22-95 <table border="1"> <thead> <tr> <th>Y/M/D</th> <th>degC</th> <th>mm</th> </tr> </thead> <tbody> <tr> <td>02/12/04</td> <td>19.2</td> <td>9.33</td> </tr> <tr> <td>03/01/06</td> <td>19.0</td> <td>36.33 ↑</td> </tr> <tr> <td>03/01/07</td> <td>18.9</td> <td>36.33</td> </tr> <tr> <td>03/01/07</td> <td>18.9</td> <td>37.42</td> </tr> <tr> <td>03/01/07</td> <td>18.8</td> <td>37.43</td> </tr> <tr> <td>03/01/07</td> <td>18.7</td> <td>55.49</td> </tr> </tbody> </table> <input type="button" value="RE-SELECT"/> <input type="button" value="SAMPLE"/>	Y/M/D	degC	mm	02/12/04	19.2	9.33	03/01/06	19.0	36.33 ↑	03/01/07	18.9	36.33	03/01/07	18.9	37.42	03/01/07	18.8	37.43	03/01/07	18.7	55.49	<b>ID:</b> HBMS - 0212-22-95 <b>DATE:</b> 2003/02/04 <b>TIME:</b> 10:46 <b>TEMPERATURE (C):</b> 19.9 <b>ABS DISP (mm):</b> 61.51 <b>REL DISP (mm):</b> 52.18 <b>RATE (mm/day):</b> 0.422 INITIALIZING... <input type="button" value="RE-SELECT"/> <input type="button" value="SAVE"/>
Y/M/D	degC	mm																					
02/12/04	19.2	9.33																					
03/01/06	19.0	36.33 ↑																					
03/01/07	18.9	36.33																					
03/01/07	18.9	37.42																					
03/01/07	18.8	37.43																					
03/01/07	18.7	55.49																					

Figure 7. PalmOS screens using MineScope to read data directly using the IrDA SensorSync module.

## **Telemetry and Networks.**

Perhaps the most compelling argument in favour of digital sensors is the ease with which components can be built into networks so that the data can be automatically transmitted to surface and beyond. Based on this advantage YieldPoint has developed **DESTINY** (**D**igitally **E**nabled **S**ensor **T**ransducer and **I**nstrumentation Network by YieldPoint) a low-cost data transmission network that can interface with a mines information infrastructure. DESTINY is based on industry standard EIA-RS 485 (ISO 8482) standard running Modbus™ ASCII protocol. Mines already using this kind of SCADA (Supervisory Control And Data Acquisition) system can seamlessly interface YieldPoint products directly to the existing network.

On the upstream end, DESTINY interfaces with all types YieldPoint instruments, and also Vibrating wire technology (eg. The VBS-2 Stress cell) and conventional potentiometric GMMs, or in fact any sensor with a 0-5Volt output sensors, 4-20ma Sensors or Frequency output.

On the downstream end, DESTINY can interface with the mine's leaky feeder communication system, any Ethernet network, or even send data directly over the ESG micro-seismic system, so offering an integration of conventional instrumentation data with micro-seismic data.

## **Conclusion**

Due to the ongoing revolution in digital electronics and communications, significantly more cost-effective geotechnical instruments can now be built using **digital** technology. The new generation of digital sensors have embedded microcontrollers that provide accurate (individual calibration) output data directly in "real world units" that can be instantly interpreted. Robust digital output signals can be transmitted across existing wireless communication networks or an ESG seismic system, collected directly using infra-red enabled PDA's and parsed into memory by low-cost data-loggers, so eliminating the costs and labour associated with data collection. At the control point, data can be stored directly into a database (rather than spreadsheet) application, and based on a comparison between trends in the stored data and user-defined thresholds can launch e-mail alerts to technicians, engineers, supervisors, or consultants.

## **REFERENCES**

Fradden , J. 1996, Handbook of Modern Sensors. 2<sup>nd</sup> Edition, Springer-Verlag, New York. 556pp.